



**INTERNATIONAL JOURNAL OF ENGINEERING SCIENCES & RESEARCH
TECHNOLOGY**

**ELECTRONIC BRAKE ASSIST SYSTEM (EBAS) IN AUTOMOBILE WITH WIRE
BRAKE**

P.Vignesh¹, K.Vinodh Simmon² & D.Siva Kumar³

^{*1} M.Tech Scholar, Bharath Institute Of Higher Education and Research, Chennai.

² M.Tech Scholar, Bharath Institute Of Higher Education and Research, Chennai.

³ PhD Research Scholar, Anna University CEG Campus, Chennai

DOI: 10.5281/zenodo.1147618

ABSTRACT

With increasing innovations in the field of Automotive Electronics, X – by wire, is becoming popular across the world. It is a system, which gets input from the driver as communication signal or electrical signal rather than the mechanical input. Mechanical linkages are not used which improves the life of the system. Brake by wire uses sensor signals from the driver to brake the vehicle. It uses sensors like Brake pedal sensor, Vehicle speed sensor. The input from the sensor is given to the ECU, which processors, the information understanding the situation and gives the output to the brakes. The brake force depends on the Speed of the vehicle, Pedal travel, Speed of pedal travel, brake pad wear. The scope of this RESEARCH includes, design and fabrication of Brake Assist System using Brake by wire technology. The Microcontroller controls the actions of the brake on the vehicle. X – by wire is a general term used to denote controlling of vehicle by wire method (Brake by wire, Drive by wire, Steer by wire).

KEYWORDS: Automotive electronics, Microprocessor, Brake assist system, Micro-controller.

I. INTRODUCTION

Motor vehicles braking systems have changed dramatically over the years. The first commonly used brake was the drum brake which used a self-energizing action to obtain a mechanical advantage and therefore generate the high necessary forces with a reasonable pedal effort. The drum brake suffered badly from brake fade, where the braking performance diminished as they heated, and also suffered from a non-linear response to pedal force. These two factors combined made the brakes very difficult to control. As the weight and speeds of vehicles increased, the braking forces also increased, and it was realized that a new braking method was necessary to ensure safe braking. This is when the disk brake was conceived. Disk brakes use hydraulics to obtain a mechanical advantage, but also require vacuum assist to create the ever-increasing braking forces.

As technology has advanced, active braking systems have been developed to assist drivers in emergency situations to improve safety. We are now experiencing the birth of the next level in active braking; Brake by Wire (BBW) where the braking signal is passed electronically to the brakes. These systems have the advantage of allowing more advanced active braking schemes, hence improving vehicle safety. There has also been a major push towards the use of electric vehicles over the last few years, with some major car manufactures commercially producing electric vehicles. Unlike combustion engines, electric vehicles don't have a natural vacuum so the brake assist must be created externally, resulting in the need for either an additional vacuum pump or hydraulic pumps, increasing the weight and cost of the braking system. This was the driving force, which leads to the idea of Electronic Brake-by-Wire (EBBW). This concept uses an electro-mechanical actuator to generate the braking forces.

II. NEED OF BRAKE BY WIRE

Standard braking systems use a proportioning valve to divide the braking pressure between the front and rear wheels, resulting in less than optimal braking performance. For any point above the ideal brake distribution line in Figure, the rear wheels will lock before the front wheels, causing the car to become unstable Thus for safety

reasons; the proportioning valve must ensure the front wheels lock first. At moderate braking levels (0.2-0.5g's) on low friction surfaces, the front brakes will lock prematurely, reducing the maximum deceleration of the car.

The situation is even worse when the car is on two surfaces with different coefficients of friction (i.e. one wheel hits a patch of ice) as the wheel with the lowest traction will lock first, possibly causing the car to become unstable. ABS overcomes this problem by reducing the braking pressure to skidding wheels, but is a reactive system, not a response one. More advanced predictive braking schemes are possible, but in order to be implemented correctly, the system must be able to actuate each brake fully independently. Brake by Wire systems provides us with the opportunity to implement these and other advanced braking schemes by removing the mechanical link between the driver and the brakes.

Research goal

This RESEARCH aims in designing a Brake by Wire system with Brake Assistance suitable for trailer vehicles. As weight and speed increases, the braking system needs to be more effective which provide shorter stopping distance. As trailer vehicles need to be engaged and disengaged frequently conventional braking system is not suitable for trailers. So, electromechanical brakes need to be used. This braking system can also be used for electric vehicles. The existing technology is inadequate for an electric vehicle with wheel motors; a new concept has been developed to solve the needs. **The ultimate aim of this RESEARCH is to develop a demo model of the brake controller needed for the trailers with Brake Assistance**

Research structure

After a brief introduction, chapter 2 provides information about the literature survey needed for this RESEARCH. The various works done on this technology are precisely described in this chapter.

Chapter 3 reviews information about BBW, BAS and its necessity. It also describes the working of BAS and electro-mechanical brakes. It also provides information about the electromagnetic brakes.

Chapter 4 describes the work done on this RESEARCH. It reviews about the block diagram and explains the circuit for this RESEARCH.

Chapter 5 describes about the components used in this RESEARCH. And finally the last chapter concludes the RESEARCH and gives information about the future scope of the RESEARCH.

Need for the research

With increase in weight and speed of vehicles, safety has become a major issue. Much development is being taken place in passenger cars, but the development of commercial vehicles is comparatively lesser. This RESEARCH emphasizes, the safety of commercial vehicles and development of brakes in electric vehicles.

This RESEARCH describes the electro-mechanical braking (EMB) system and the design basics of its control based on 8051 microcontroller. Electro-mechanical braking systems also referred to as brake by-wire, replace conventional hydraulic braking systems with a completely dry electrical component system. This occurs by replacing conventional actuators with electromagnets or electric motor-driven units. This move to electronic control eliminates many of the manufacturing, maintenance, and environmental concerns associated with hydraulic systems. As in electro-hydraulic braking (EHB), EMB can be designed to improve connectivity with other vehicle systems, thus enabling simpler integration of higher-level functions, such as traction control and vehicle stability control. This integration may vary from embedding the function within the EMB system, as with ABS, to interfacing to these additional systems via communication links.

Another advantage of EMB systems is the elimination of the large vacuum booster found in conventional systems. An increase in flexibility for the placement of components is also provided by EMB systems, compared to those of EHB, with the total elimination of the hydraulic system.

III. BRAKE BY WIRE AND BAS

Standard braking systems use a proportioning valve to divide the braking pressure between the front and rear wheels, resulting in less than optimal braking performance. For any point above the ideal brake distribution, the rear wheels will lock before the front wheels, causing the car to become unstable. Thus for safety reasons, the

proportioning valve must ensure the front wheels lock first. At moderate braking levels (0.2-0.5g's) on low friction surfaces, the front brakes will lock prematurely, reducing the maximum deceleration of the car.

The situation is even worse when the car is on two surfaces with different coefficients of friction (i.e. one wheel hits a patch of ice), as the wheel with the lowest traction will lock first, possibly causing the car to become unstable. ABS overcomes this problem by reducing the braking pressure to skidding wheels, but is a reactive system, not a response one. More advanced predictive braking schemes are possible, but in order to be implemented correctly, the system must be able to actuate each brake fully independently. Brake by Wire systems provides us with the opportunity to implement these and other advanced braking schemes by removing the mechanical link between the driver and the brakes

Brake by wire

With the Electro Mechanical Brake we are getting involved in pure brake-by-wire technology, which eliminates brake fluids and hydraulic lines entirely. The braking force is generated directly at each wheel by high performance electric motors or electromagnet. They are controlled by an Electronic Control Unit (ECU) and actuated by signals from an electronic pedal module.

Brake-by-wire systems use an electrically controlled actuator to provide a braking force. These actuators are usually either electro-hydraulic systems or electromechanical systems. The electro-hydraulic systems work like a conventional brake in the sense that they use a hydraulic force to drive a piston onto the braking surface, but the force is generated electrically, usually through hydraulic pumps and servo valves. These systems often incorporate mechanical backup to ensure braking is still possible even if the electrical system fails.

Electro-mechanical systems use an electric actuator to generate the braking force, with the designs usually providing no possibility for a mechanical link between the driver and the brakes. The electro-mechanical systems have the potential to be much lighter than the electro-hydraulic systems, and are often more efficient as they don't require a pump to be running all the time, but the lack of mechanical backup is usually undesired. An additional mechanical backup is usually added to ensure braking is possible in the event of complete failure of the power supply. Electromechanical systems have the potential to be more reliable than the electro-hydraulic systems as the systems can involve less moving parts, with the reliability ultimately determined by the reliability of the electrical system.

Brake assist system

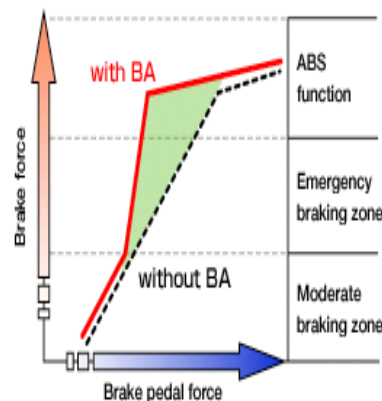

Figure 3.1 – Brake Pedal Force Vs Brake Force

A brake assist system monitors the driver's use of the brake pedal, automatically sensing an attempt to stop the car as a result of panic. It then generates very high braking power, even when the driver is only pressing lightly on the brake pedal. This illustration is shown in Figure 3.1. When this is used together with anti-lock braking systems, it results in faster and safer braking. Depending on the driver, statistics for emergency stops in cars using this technology range from a 20% - 45% reduction in stopping distances, a potentially significant difference in critical situations.

Some road tests show that a driver needs up to 240 feet (73 meters) to stop a car going approximately 60 mph (100 km/h). In the same scenario, cars with brake assist were able to come to a complete stop in as little as 130 feet (40 meters). Since it only takes one-fifth of a second to travel a car length at highway speeds, the superior speed with which the brakes assist is able to react also accounts for its improved safety results over traditional braking systems.

Working of bas

A car equipped with a brake assist system has electronic components that monitor the speed with which the brake is applied. A small computer keeps track of how the driver typically apply the brake as the driver drives the car, both how quickly and how firmly, and learns what the particular pattern is. As it builds up the information, it is able to recognize when the driver has applied the brakes much faster than usual, and interprets that this is a result of a critical situation and automatically triggers the brake assist system. When the system is triggered, it immediately factors in brake wear and current speed to determine the amount of force that is needed to stop the car.

1. The driver does not press the brake forcefully enough in case of an emergency. Therefore, not enough braking force is generated.
2. Usually, the driver decreased his/her pressure on the brake pedal after "slamming" it initially, causing a further reduction of braking force.
3. When the driver presses the brake pedal more rapidly then normal, brake assist automatically recognizes the situation as Emergency braking and increases the braking force.

After the emergency brake situation, when the driver releases the brake pedal, the brake assist system reduces the amount of force simultaneously.

Braking systems overview

The need for better fuel economy, simplified system assembly, more environmentally friendly systems, ease of vehicle maneuverability, and improved safety systems has resulted in new types of braking systems.

The centerpiece of the current braking systems is a hydraulic assembly under the hood of the vehicle that brings together the electronic control unit, wheel pressure modulators, pressure reservoir, and electric pump. The interaction of mechanics and electronics is key to the success of the braking system. The microcomputer, software, sensors, valves, and electric pump work together to form the basis of the system.

Electro-Hydraulic brakes

Compared to the operation of conventional braking systems, by depressing the brake pedal with the Electro-Hydraulic Braking System (EHB), the appropriate command is transmitted electronically to the electronic controller of the hydraulic unit. This determines the optimum braking pressure and actuates the brake calipers hydraulically

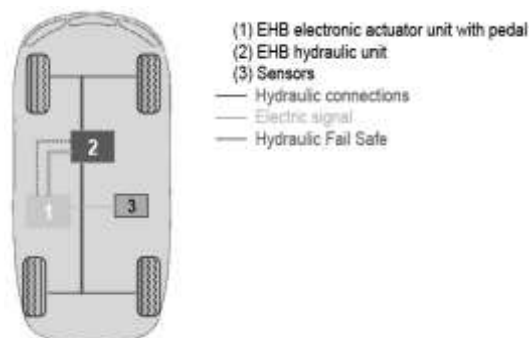

Figure 3.2 – Electro Hydraulic Brakes

Electro-Mechanical brake

The Electro-Mechanical Braking Systems represents a complete change in requirements from the previous hydraulic braking systems. The EMB involves in pure brake-by-wire technology, which dispenses with brake fluids and hydraulic lines entirely. The braking force is generated directly at each wheel by electromagnets or high-performance electric motors, controlled by an ECU, and executed by signals from an electronic pedal module. With EBM all brake and stability functions can be easily incorporated, such as the Anti-lock Braking

[Vignesh* *et al.*, 7(1): January, 2018]

IC™ Value: 3.00

System (ABS), Electronic Brake Distribution (EBD), Traction Control System (TCS), Electronic Stability Program (ESP), Brake Assist System (BAS), and Adaptive Cruise Control (ACC). It is virtually noiseless, even in ABS mode.

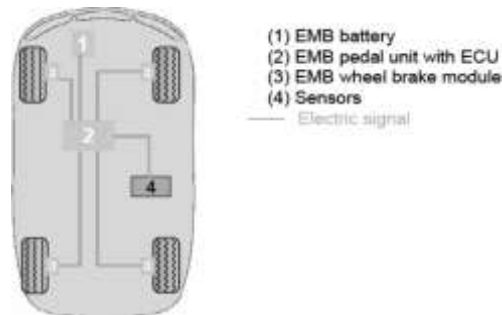

Figure 3.3 – Electro Mechanical Brakes

Advantages of the EMB

- Shorter stopping distances and optimized stability
- More comfort and safety due to adjustable pedals
- No pedal vibration in ABS mode
- Virtually silent
- Environmentally friendly with no brake fluid
- Saves space and uses fewer parts
- Simple assembly
- Capable of realizing all the required braking and stability functions, such as ABS, EBD, TCS, ESP, BA, ACC, etc.
- Can easily be networked with future traffic management systems

Elements of an electronic braking system

An advanced braking system, such as a brake wheel node, generally contains the following elements:

- a. Sensors
- b. Electronic control module (ECM)
- c. Electric motor actuator (or) Electromagnet
- d. Gear-reduction mechanism (not used if actuator is an electromagnet)

The ECM controller is partitioned into several blocks, including:

- a. Sensor input processing
- b. Microcontroller
- c. Power electronics and input relay
- d. System-basis chip
- e. Communication

EMB actuation

The characteristics of each EMB system are determined by both hardware and software. The software plays a greater role in defining the character and brand of the new brake systems in vehicles, and the vehicle manufacturer, as system integrator, must define the behavior of the vehicle in terms of function, performance, comfort, endurance, safety, etc., Advanced braking functions such as anti-lock braking, traction control, vehicle stability, and chassis control allow optimization of vehicle braking and stability, but are not required for basic deceleration performance.

Electromagnetic brake

The electromagnetic brakes main parts are

1. Magnet
2. Actuating arm
3. Adjuster

4. Adjuster spring
5. Reactor spring
6. Hold down spring
7. Shoe and lining

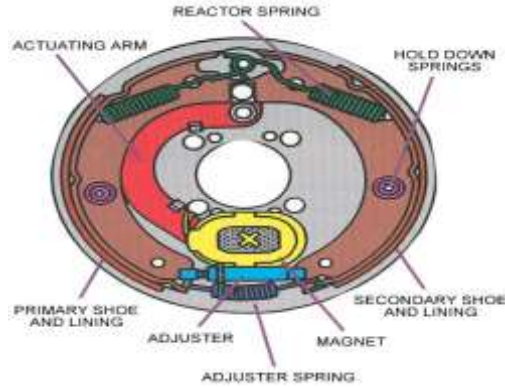

Figure 3.4 – Electromagnetic brake assembly

When current is supplied to the electromagnet, it attracts the actuating arm and rotates the cam as in conventional drum brake and the reactor spring holds the shoes in position. As the current increases, the force produced by the electromagnet increases and correspondingly, the actuating arm and shoe. The adjuster is used to adjust the position of the brake shoe.

Electromagnetic brakes could also be used in disc brakes. Here, repulsive force is used for braking. The repulsive force repels the brake shoe in the disc brake and hence the braking action.

In brake by wire technology, the actuation of the brake shoe need not be by an electromagnet. A motor can actuate the cam. The torque developed by the motor may not be sufficient to stop the vehicle, so a reduction gear is used to develop more torque. The same principle can be used for disc brake also. However the response of the system with a motor is lesser than an electromagnetic brake as the response of the motor is slow. Rotational motion of the motor needs to be converted into linear motion in case of disc brake to actuate the brake pad.

IV. ELECTRONIC CONTROL SYSTEM

Block Diagram of the System

The system has a pedal position sensor on the brake pedal. The position sensor senses the pedal's position at any time as depressed by the driver. Since, the position of pedal varies depending on the situation, the output from the position sensor also varies. The entire system works on the supply of 12V battery. The system also has a speed sensor, which informs about the speed of the vehicle. The speed sensor mounted on the wheels gives pulses. The brake controller counts the number of pulses per second and determines the speed. The output from the position sensor and the speed sensor is given to the brake controller, which controls the entire system. The brake controller is an 8051 Microcontroller capable of being programmed by the programmer. The output to the system is given to the electromagnetic brakes. The electromagnetic brakes operate on a 12V supply. This electromagnetic brake, brakes the vehicle. The architecture of the system is shown in Figure 4.1.

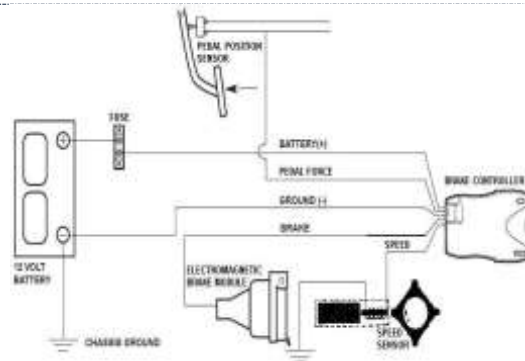

Figure 4.1 – Block Diagram of the System

The force generated at the electromagnet to brake the vehicle is proportional to the current output from the brake controller. As the current output from the brake controller increases the braking force also increases. The position of the brake pedal is a critical value for determining the brake force required on the wheels.

Block Diagram Of The Controller

The outputs from the sensors are in the form of analog signals. For the computer to process these signals the analog signals need to be converted into digital signal, as the computer is a digital processor. These analog signals are converted into digital signals using an Analog to Digital Converter (ADC). The ECU (or) the Microcontroller processes the data using the input signals and gives the output in digital form. The output in the digital form is converted into analog signals using a Digital to Analog Converter (DAC). The converted analog signals are amplified using a driver circuit for the electromagnetic brakes to operate. The devices used for signal processing are ADC, DAC and the Driver Circuit. They are illustrated in Figure 4.2.

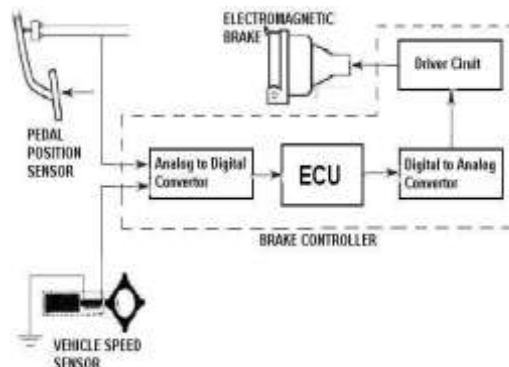

Figure 4.2 – Block Diagram of the Controller

Formula for calculation

The braking force required for stopping the vehicle and correspondingly the current has been calculated and is shown in Table 4.1 to Table 4.4. The mass of the vehicle is assumed to be 10,000kg. This electromagnetic braking is used for electric vehicles and trailer vehicles. These vehicles do not move at a speed greater than 16.67ms⁻¹ (60kmph). So, the brake force is computed for speed range between 1.39ms⁻¹ (5kmph) and 16.67ms⁻¹ (60kmph). The brake pedal travel is proportional to the stopping time. The braking time varies from 5.65 seconds to 2.43 seconds. More the pedal is depressed the stopping time also reduces. The brake pedal has an internal potentiometer to sense the pedal position. It has a variable resistance of 2kΩ. For sensing the vehicle speed, an optical pickup sensor is used. The brake force required is calculated using the formula

$$F = m.a \quad a = V / t$$

- Where, F – Force required
- m – Mass of the vehicle
- a – Deceleration of the vehicle.
- V – Velocity of the vehicle during braking
- t – Time required to stop the vehicle

[Vignesh* *et al.*, 7(1): January, 2018]
 IC™ Value: 3.00

The current required to produce the braking force is calculated from the formula 4.3.1 Formula To Calculate Current Required

$$F = [\mu N^2 I^2 A / 2 L^2]^2$$

Where, F – Force (Newton)

$$\mu = 4\pi \times 10^{-7}$$

N – Number of turns

I – Current (Ampere)

A – Area of the magnet face (m²)

L – Length of the magnet (m)

From Catalogue

N = 15000 turns

A = 706 x 10⁻⁶ m² (Dia = 30mm)

L = 50mm = 50 x 10⁻³m

Table 4.1 – Normal Force (kN)

Velocity	1.39	2.78	4.17	5.56	6.94	8.33	9.72	11.11	12.50	13.89	15.28	16.67
Pedal Travel %												
5.00	2.46	4.92	7.38	9.83	12.29	14.75	17.21	19.67	22.13	24.58	27.04	29.50
10.00	2.53	5.07	7.60	10.14	12.67	15.21	17.74	20.28	22.81	25.35	27.88	30.41
15.00	2.62	5.23	7.85	10.46	13.08	15.69	18.31	20.92	23.54	26.15	28.77	31.39
20.00	2.70	5.40	8.11	10.81	13.51	16.21	18.91	21.61	24.32	27.02	29.72	32.42
25.00	2.79	5.59	8.38	11.18	13.97	16.76	19.56	22.35	25.15	27.94	30.73	33.53
30.00	2.89	5.79	8.68	11.57	14.46	17.36	20.25	23.14	26.03	28.93	31.82	34.71
35.00	3.00	6.00	9.00	11.99	14.99	17.99	20.99	23.99	26.99	29.99	32.98	35.98
40.00	3.11	6.23	9.34	12.45	15.56	18.68	21.79	24.90	28.01	31.13	34.24	37.35
45.00	3.24	6.47	9.71	12.94	16.18	19.41	22.65	25.88	29.12	32.36	35.59	38.83
50.00	3.37	6.74	10.11	13.47	16.84	20.21	23.58	26.95	30.32	33.69	37.05	40.42
55.00	3.51	7.03	10.54	14.05	17.57	21.08	24.59	28.11	31.62	35.13	38.64	42.16
60.00	3.67	7.34	11.01	14.68	18.35	22.02	25.69	29.36	33.04	36.71	40.38	44.05
65.00	3.84	7.69	11.53	15.37	19.21	23.06	26.90	30.74	34.59	38.43	42.27	46.11
70.00	4.03	8.06	12.10	16.13	20.16	24.19	28.22	32.26	36.29	40.32	44.35	48.38
75.00	4.24	8.48	12.72	16.96	21.20	25.45	29.69	33.93	38.17	42.41	46.65	50.89
80.00	4.47	8.94	13.42	17.89	22.36	26.83	31.31	35.78	40.25	44.72	49.20	53.67
85.00	4.73	9.46	14.19	18.92	23.65	28.39	33.12	37.85	42.58	47.31	52.04	56.77
90.00	5.02	10.04	15.06	20.08	25.10	30.13	35.15	40.17	45.19	50.21	55.23	60.25
95.00	5.35	10.70	16.05	21.40	26.74	32.09	37.44	42.79	48.14	53.49	58.84	64.19
100.00	5.72	11.45	17.17	22.89	28.61	34.34	40.06	45.78	51.50	57.23	62.95	68.67

Table 4.2 – Emergency Force (kN)

Velocity	1.39	2.78	4.17	5.56	6.94	8.33	9.72	11.11	12.50	13.89	15.28	16.67
Pedal Travel %												
35.00	4.50	9.00	13.49	17.99	22.49	26.99	31.49	35.98	40.48	44.98	49.48	53.97
40.00	4.67	9.34	14.01	18.68	23.34	28.01	32.68	37.35	42.02	46.69	51.36	56.03
45.00	4.85	9.71	14.56	19.41	24.27	29.12	33.97	38.83	43.68	48.53	53.39	58.24
50.00	5.05	10.11	15.16	20.21	25.26	30.32	35.37	40.42	45.48	50.53	55.58	60.64
55.00	5.27	10.54	15.81	21.08	26.35	31.62	36.89	42.16	47.43	52.70	57.97	63.24
60.00	5.51	11.01	16.52	22.02	27.53	33.04	38.54	44.05	49.55	55.06	60.56	66.07
65.00	5.76	11.53	17.29	23.06	28.82	34.59	40.35	46.11	51.88	57.64	63.41	69.17
70.00	6.05	12.10	18.14	24.19	30.24	36.29	42.34	48.38	54.43	60.48	66.53	72.58
75.00	6.36	12.72	19.08	25.45	31.81	38.17	44.53	50.89	57.25	63.61	69.97	76.34
80.00	6.71	13.42	20.13	26.83	33.54	40.25	46.96	53.67	60.38	67.09	73.80	80.50
85.00	7.10	14.19	21.29	28.39	35.48	42.58	49.67	56.77	63.87	70.96	78.06	85.16
90.00	7.53	15.06	22.59	30.13	37.66	45.19	52.72	60.25	67.78	75.31	82.84	90.38
95.00	8.02	16.05	24.07	32.09	40.12	48.14	56.16	64.19	72.21	80.23	88.26	96.28
100.00	8.58	17.17	25.75	34.34	42.92	51.50	60.09	68.67	77.26	85.84	94.42	103.01

Research Design

Table 4.3 – Normal Current (A)

Velocity	1.39	2.78	4.17	5.56	6.94	8.33	9.72	11.11	12.50	13.89	15.28	16.67
Pedal Travel %												
5.00	1.11	1.33	1.47	1.58	1.67	1.74	1.81	1.87	1.93	1.98	2.03	2.07
10.00	1.12	1.34	1.48	1.59	1.68	1.76	1.83	1.89	1.94	2.00	2.04	2.09
15.00	1.13	1.35	1.49	1.60	1.69	1.77	1.84	1.90	1.96	2.01	2.06	2.11
20.00	1.14	1.36	1.50	1.61	1.71	1.79	1.86	1.92	1.98	2.03	2.08	2.12
25.00	1.15	1.37	1.51	1.63	1.72	1.80	1.87	1.93	1.99	2.05	2.10	2.14
30.00	1.16	1.38	1.53	1.64	1.74	1.82	1.89	1.95	2.01	2.06	2.11	2.16
35.00	1.17	1.39	1.54	1.66	1.75	1.83	1.90	1.97	2.03	2.08	2.13	2.18
40.00	1.18	1.41	1.56	1.67	1.77	1.85	1.92	1.99	2.05	2.10	2.15	2.20
45.00	1.19	1.42	1.57	1.69	1.78	1.87	1.94	2.01	2.07	2.12	2.17	2.22
50.00	1.21	1.43	1.59	1.70	1.80	1.89	1.96	2.03	2.09	2.14	2.20	2.24
55.00	1.22	1.45	1.60	1.72	1.82	1.91	1.98	2.05	2.11	2.17	2.22	2.27
60.00	1.23	1.46	1.62	1.74	1.84	1.93	2.00	2.07	2.13	2.19	2.24	2.29
65.00	1.25	1.48	1.64	1.76	1.86	1.95	2.03	2.10	2.16	2.22	2.27	2.32
70.00	1.26	1.50	1.66	1.78	1.89	1.97	2.05	2.12	2.18	2.24	2.30	2.35
75.00	1.28	1.52	1.68	1.81	1.91	2.00	2.08	2.15	2.21	2.27	2.33	2.38
80.00	1.29	1.54	1.70	1.83	1.94	2.03	2.10	2.18	2.24	2.30	2.36	2.41
85.00	1.31	1.56	1.73	1.86	1.96	2.05	2.13	2.21	2.27	2.33	2.39	2.44
90.00	1.33	1.58	1.75	1.88	1.99	2.08	2.17	2.24	2.31	2.37	2.43	2.48
95.00	1.35	1.61	1.78	1.91	2.02	2.12	2.20	2.28	2.34	2.41	2.46	2.52
100.00	1.38	1.64	1.81	1.95	2.06	2.15	2.24	2.31	2.38	2.45	2.51	2.56

Hardware Design

The hardware design is divided into four parts

1. Power Supply
2. Input
3. Processor
4. Output

The circuit is designed using Or CAD software Release 9.

Power supply

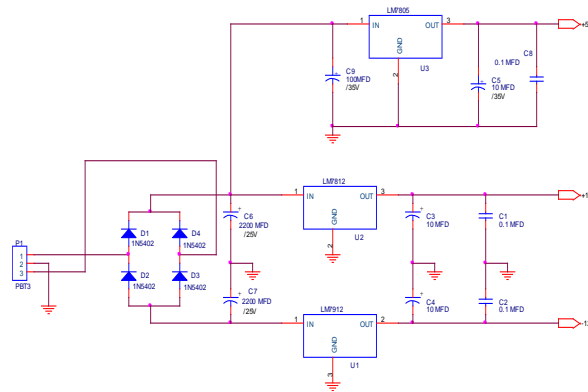

Figure 4.3 – Power Supply Circuit Diagram

The circuit shown in Figure 4.3 converts the AC voltage into DC voltage and supplies the power required for the system. The real application works on DC supply from the battery. The digital circuits work on 5VDC and the analog circuits work on 12VDC. For demonstration purpose, instead of a battery, power from AC socket is used. This AC is converted into DC and regulated using the regulators 7805, 7812 and 7912. 7805, 7812 and 7912 are +5VDC, +12VDC and -12VDC regulators respectively. Power from the power circuit is utilized as necessary using connector pins. Capacitors in the circuit act as filters. During rectification process, some AC components are left out. Capacitors are used to filter these AC components preventing from entering the circuit. Before the AC is rectified, the AC needs to be step down to the required voltage. In our application, it is step down to 12VAC using a transformer.

Input

The input sensors are two in number. They are the vehicle speed sensor and pedal position sensor. For the vehicle speed sensor, an optical pickup sensor is used. The circuit of the optical pickup sensor is shown in 4.4 below.

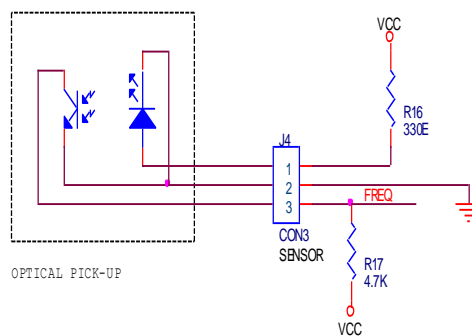

Figure 4.4 – Vehicle speed sensor Circuit

The optical pickup observes a once-per-turn event marker on the shaft. It generates a voltage pulse that becomes the timing and phase reference signal for speed, phase angle and frequency measurements. However in this RESEARCH, only speed measurements. This measurement enables us to correlate the instantaneous velocity of the shaft. The optical sensor is isolated with an opto-isolator.

In electronics, an opto-isolator is a device that uses a short optical transmission path to transfer a signal between elements of a circuit, typically a transmitter and a receiver, while keeping them electrically isolated. The signal goes from an electrical signal to an optical signal back to an electrical signal; electrical contact along the path is broken.

[Vignesh* *et al.*, 7(1): January, 2018]
IC™ Value: 3.00

The other input, pedal position sensor is received as voltage signal, which is in analog form. Since, the microcontroller understands only digital signals, the input from the pedal position sensor is connected to the ADC. The ADC converts the analog input from the position sensor into digital signal.

In addition to these two inputs, sensors like brake pad wear, weight transfer, yaw, roll and pitch can be sensed using appropriate sensors for future development RESEARCH.

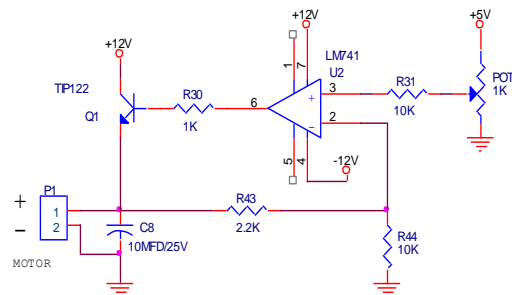

Figure 4.5 Motor driver Circuit

The Figure 4.5 shows the motor driver circuit. To sense the speed of the vehicle, a setup is made with variable speed motor. The rotation of the motor is assumed to be the rotation of the wheel. This circuit helps in varying the speed of the motor for a virtual demonstration. The speed is varied with a potentiometer and a non-inverting amplifier. The transistor TIP122 is a constant voltage source transistor. The base current is varied and hence to voltage at the emitter. A feedback is established by a closed loop with the op-amp. This feedback ensures that the voltage is as required to maintain the speed of the motor.

Processor

The ECU works on an 8051 microcontroller. The peripheral circuits needed for the interface are also designed.

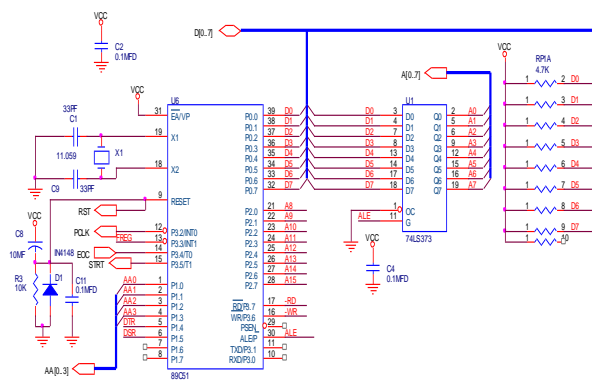

Figure 4.6 – Microcontroller and its peripherals

This Figure 4.6 shows the circuit of the 8051 microcontroller. It is connected to a crystal of 11.059MHz. A decoupling capacitor is used in all the IC's. A Decoupling capacitor is a capacitor used to decouple one part of an electrical network (circuit) from another. That means it makes one part of a circuit unaffected by things going on in another part of the circuit.

One common kind of decoupling is of a powered circuit from signals in the power supply. Sometimes for various reasons a power supply supplies an AC signal superimposed on the DC power line. Such a signal is often undesirable in the powered circuit. A decoupling capacitor can prevent the powered circuit from seeing that signal, thus decoupling it from that aspect of the power supply circuit.

The microcontroller has a reset (RST) on power on. The ADC (Analog to Digital Converter) requires a clock pulse for its operation. This clock pulse is generated in the software. The ADC requires a start command

[Vignesh* *et al.*, 7(1): January, 2018]
IC™ Value: 3.00

(STRT) to start the conversion process and on completion of the conversion process, it sends a End of Conversion (EOC) to the microcontroller. Ports are used for these signals to be sent and be received.

Port 0 is used as data bit for the ADC. Port 0 has a low pull up. So pull up resistors are used to increase the same. A resistor pack is used for the pull up resistors. Edge triggered flip flops are used to separate the address and the data from the port 0.

Port 1 is used to address the ADC. This address bit is used to select the input analog channel of the ADC. This ADC has 8 input channels. In our application we use only one channel. We have selected channel 0 for the pedal position. So, all the address lines are kept low always.

Port 2 is used for the decoder select circuit. The decoder selects the device to which the data is to be sent.

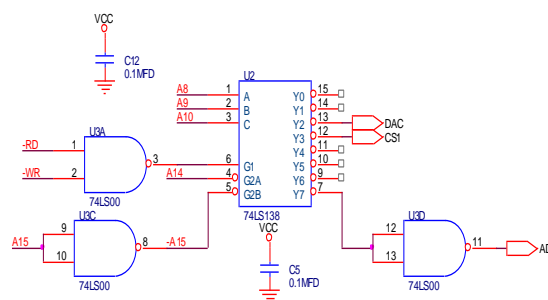

Figure 4.7 – Decoder Circuit

This circuit in Figure 4.7 shows the decoder circuit. It is used to select the IC to which the data is to be sent. Address lines A8, A9 and A10 are used to select the outputs. A14 and A15 are used as enable lines. The DAC and the display select chip are high enable. ADC is a low enable chip. So, a NAND gate is used to invert the signal. The DAC uses it as clock pulse for its operation. ADC uses to enable the output.

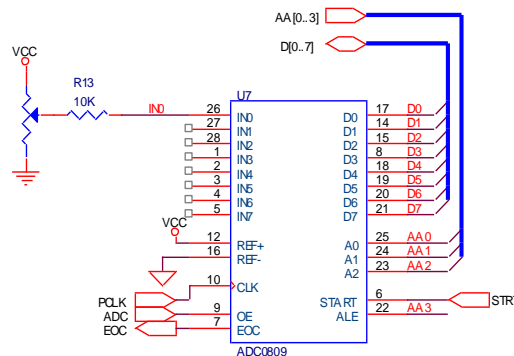

Figure 4.8 – Analog to Digital Converter

The figure 4.8 shows the ADC circuit. It has an eight channel multiplexer with address logic. The input from the pedal position sensor is given at analog channel 0. It receives the clock pulse from the microcontroller. The clock pulse is internally programmed for its frequency. When the ADC receives the start command from the microcontroller, it starts the conversion process. When the output enable is enabled, the output is sent to the microcontroller through the data lines. On completion of the conversion process, the ADC sends an End of Conversion (EOC) signal to the microcontroller.

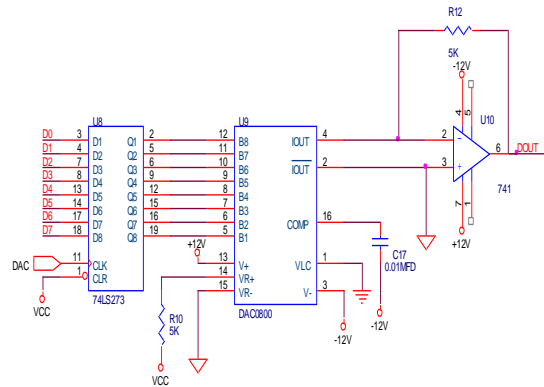

Figure 4.9 – Digital to Analog Converter

The Figure 4.9 shows the Digital to Analog Converter circuit. The data lines are sent to the DAC through an 8-bit register. 8-bit register is used to enable the DAC to receive only the data necessary to it. Since the DAC does not have an enable line, 8-bit register is used as a lock to the DAC. The DAC receives the data, and converts the digital signals into analog signal. A non-inverting amplifier amplifies this analog signal. The amplified analog signal is given to the driver circuit to drive the electromagnetic brake.

Output

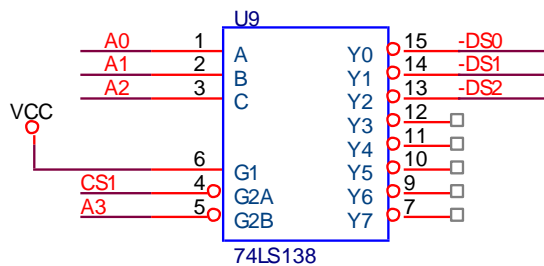

Figure 4.10 – Decoder for Display unit

The decoder used for the display circuit is show in Figure 4.10. It selects the display to which the data is to be sent. CS1 signal from the other decoder and A3 are used as enable signals. Signals A0..A3 is used to select the output channel. The output channel selects the 8-bit register corresponding to the display.

This circuit in Figure 4.11 helps in displaying the amount of current output from the driver circuit. The 8-bit registers are connected to the respective 7-segment display. The data is received from the microcontroller through the data bus. Though this data is sent to all IC's, it will be received only by the display because of the decoder. The decoder helps in sending the data to the appropriate chip.

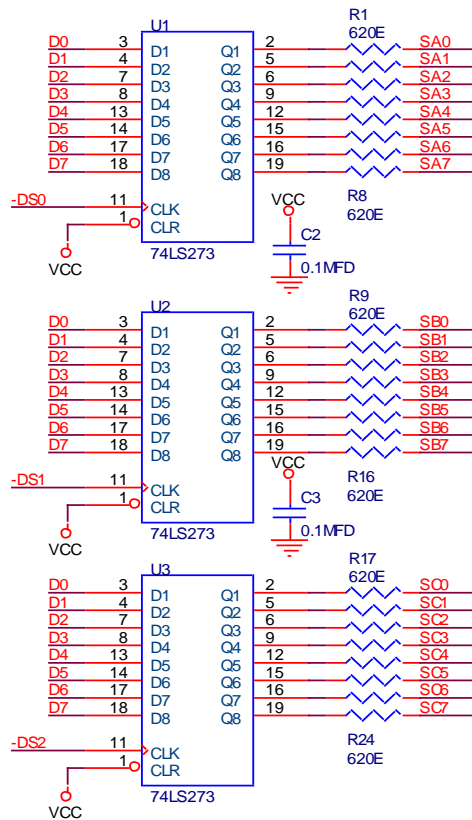

Figure 4.11 – Display select register and 7-segment display-1

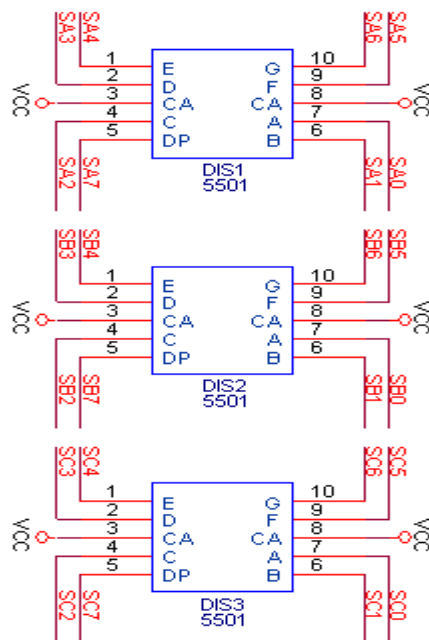

Figure 4.11 – Display select register and 7-segment display-2

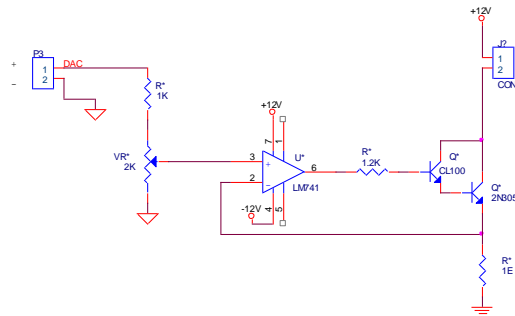

Figure 4.12 Electromagnet Driver Circuit

The Figure 4.12 shows the driver circuit for the braking system. It receives signal from the DAC. This signal received is an analog signal. It is got at the output as a constant current source. The transistors CL100 and 2N3055 give a constant current output. These two transistors make a darlington pair. Darling ton pair is used when the amplification by the transistor is not sufficient. In this application, the amplification required is as high up to 3Amperes. This constant current source is controlled by an op-amp. This op-amp is a non-inverting amplifier. It has a feedback from the output of the system, thus maintaining the constant current. The electromagnetic brake is connected at the connector 2. The current at this connector does not exceed the output value of the DAC. However a variable resistor could control the current provided at the input side of the op-amp.

Software Design

The software is the programming done on the microcontroller. For programming the 8051, op-codes and mnemonics are used which are machine level language. Another easier method of programming is by embedded programming. This programming is similar to low level language like C. For programming the 8051 microcontroller Cross'C' Compilers are used. This compiler can be used for 51 series programming. The compiler used for this RESEARCH is Avocet 'C' Compiler. The program is typed on a notepad and saved with an extension of dot C. Header files required for the program is also created in the same procedure and saved with the extension of dot H. On successful compilation of the program the program is saved with an extension of dot HEX. This HEX file is downloaded into the microcontroller through the COM port of the computer.

The software cannot be tested on the computer. It needs to be downloaded to the microcontroller and then tested.

V. DESCRIPTION OF COMPONENTS

The major components used in this RESEARCH are

1. 89C51 Microcontroller
2. ADC0809 Analog to Digital converter
3. DAC0800 Digital to Analog Converter
4. LM741 Opamp
5. 74LS138 Decoder

89C51 microcontroller

Feature of 89C51

- Compatible with MCS-51[®] Products
- 4 Kbytes of In-System Reprogrammable Flash Memory
- Endurance: 1,000 Write/Erase Cycles
- Fully Static Operation: 0 Hz to 24 MHz
- Three-Level Program Memory Lock
- 128 x 8-Bit Internal RAM
- 32 Programmable I/O Lines
- Two 16-Bit Timer/Counters
- Six Interrupt Sources
- Programmable Serial Channel

- Low Power Idle and Power Down Modes

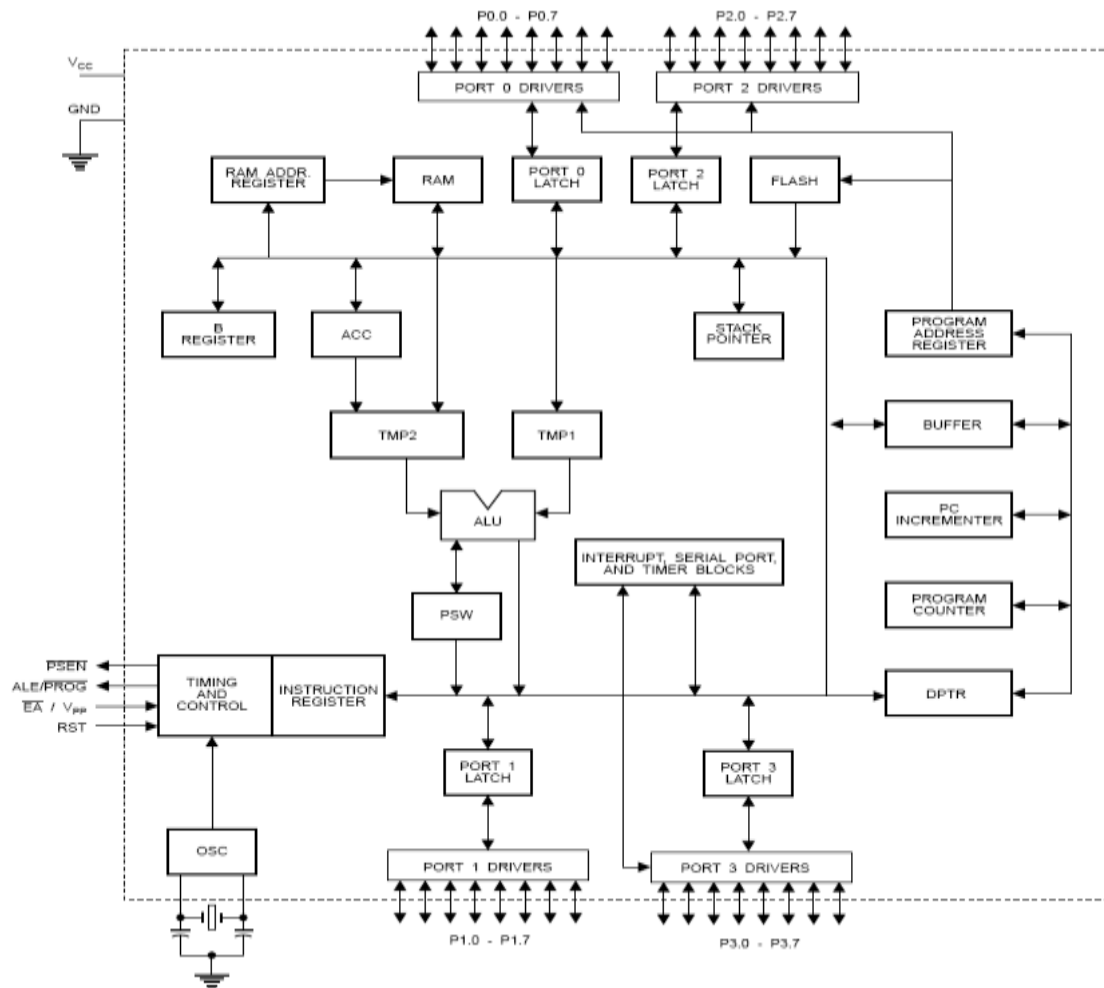

Figure 5.1 Architecture Of 89c51

The 89C51 is a type of 8051 microcontroller manufactured by Atmel. The AT89C51 is a low-power, high-performance CMOS 8-bit microcomputer with 4Kbytes of Flash Programmable and Erasable Read Only Memory (PEROM). The device is manufactured using Atmel's high-density nonvolatile memory technology and is compatible with the industry standard MCS-51TM instruction set and pinout. The on-chip Flash allows the program memory to be reprogrammed in-system or by a conventional nonvolatile memory programmer. By combining a versatile 8-bit CPU with Flash on a monolithic chip, the Atmel AT89C51 is a powerful microcomputer, which provides a highly flexible and cost effective solution to many embedded control applications. The AT89C51 provides the following standard features:

4Kbytes of Flash, 128 bytes of RAM, 32 I/O lines, two 16-bit timer/counters, a five vector two-level interrupt architecture, a full duplex serial port, and on-chip oscillator and clock circuitry.

In addition, the AT89C51 is designed with static logic for operation down to zero frequency and supports two software selectable power saving modes. The Idle Mode stops the CPU while allowing the RAM, timer/counters, serial port and interrupt system to continue functioning. The Power Down Mode saves the RAM contents but freezes the oscillator disabling all other chip functions until the next hardware reset.

PIN Configuration

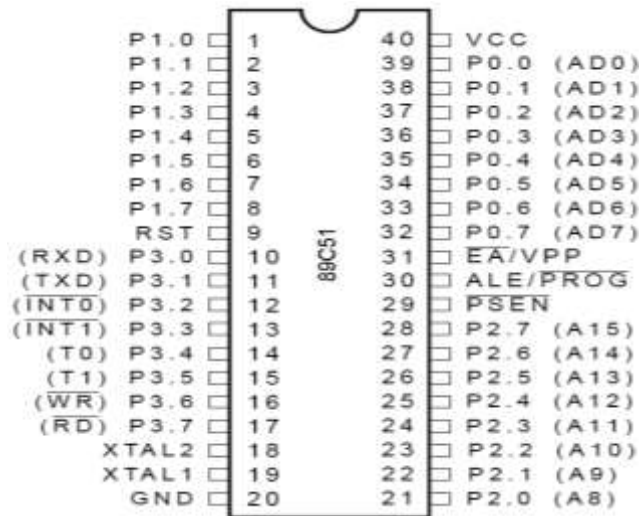

Figure 5.2 – Pin Configuration of 89C51

VCC - Supply voltage
GND - Ground

Port 0

Port 0 is an 8-bit open drain bi-directional I/O port. As an output port each pin can sink eight TTL inputs. When 1s are written to port 0 pins, the pins can be used as high-impedance inputs. Port 0 may also be configured to be the multiplexed low-order address/data bus during accesses to external program and data memory. In this mode P0 has internal pullups. Port 0 also receives the code bytes during Flash programming, and outputs the code bytes during program verification. External pullups are required during program verification.

Port 1

Port 1 is an 8-bit bidirectional I/O port with internal pullups. The Port 1 output buffers can sink/source four TTL inputs. When 1s are written to Port 1 pins they are pulled high by the internal pullups and can be used as inputs. As inputs, Port 1 pins that are externally being pulled low will source current (IIL) because of the internal pullups. Port 1 also receives the low-order address bytes during Flash programming and program verification.

Port 2

Port 2 is an 8-bit bidirectional I/O port with internal pullups. The Port 2 output buffers can sink/source four TTL inputs. When 1s are written to Port 2 pins they are pulled high by the internal pullups and can be used as inputs. As inputs, Port 2 pins that are externally being pulled low will source current (IIL) because of the internal pullups. Port 2 emits the high-order address byte during fetches from external program memory and during accesses to external data memory that uses 16-bit addresses (MOVX@ DPTR). In this application it uses strong internal pull-ups when emitting 1s. During accesses to external data memory that use 8-bit addresses (MOVX @ RI), Port 2 emits the contents of the P2 Special Function Register. Port 2 also receives the high-order address bits and some control signals during Flash programming and verification.

Port 3

Port 3 is an 8-bit bidirectional I/O port with internal pull-ups. The Port 3 output buffers can sink/source four TTL inputs. When 1s are written to Port 3 pins they are pulled high by the internal pull-ups and can be used as inputs. As inputs, Port 3 pins that are externally being pulled low will source current (IIL) because of the pullups. Port 3 also serves the functions of various special features of the AT89C51 as listed below:

Port Pin and its Alternate Functions

P3.0 - RXD (serial input port)

P3.1 - TXD (serial output port)

P3.2 - INT0 (external interrupt 0)



P3.3 - INT1 (external interrupt 1)

P3.4 - T0 (timer 0 external input)

P3.5 - T1 (timer 1 external input)

P3.6 - WR (external data memory write strobe)

P3.7 - RD (external data memory read strobe)

Port 3 also receives some control signals for Flash programming and programming verification.

RST

Reset input. A high on this pin for two machine cycles while the oscillator is running resets the device.

ALE/PROG

Address Latch Enable output pulse for latching the low byte of the address during accesses to external memory. This pin is also the program pulse input (PROG) during Flash programming. In normal operation ALE is emitted at a constant rate of 1/6 the oscillator frequency, and may be used for external timing or clocking purposes. Note, however, that one ALE pulse is skipped during each access to external Data Memory. If desired, ALE operation can be disabled by setting bit 0 of SFR location 8EH. With the bit set, ALE is active only during a MOVX or MOVC instruction. Otherwise, the pin is weakly pulled high. Setting the ALE-disable bit has no effect if the microcontroller is in external execution mode.

PSEN

Program Store Enable is the read strobe to external program memory. When the AT89C51 is executing code from external program memory, PSEN is activated twice each machine cycle, except that two PSEN activations are skipped during each access to external data memory.

EA/VPP

External Access Enable. EA must be strapped to GND in order to enable the device to fetch code from external program memory locations starting at 0000H up to FFFFH. Note, however, that if lock bit 1 is programmed, EA will be internally latched on reset. EA should be strapped to VCC for internal program executions. This pin also receives the 12-volt programming enable voltage (VPP) during Flash programming, for parts that require 12-volt VPP.

XTAL1

Input to the inverting oscillator amplifier and input to the internal clock operating circuit.

XTAL2

Output from the inverting oscillator amplifier.

Analog To Digital Convertor

ADC0809 is 8-Bit Microprocessor Compatible A/D Converters with 8-Channel Multiplexer. The ADC0809 data acquisition component is a monolithic CMOS device with an 8-bit analog-to-digital converter, 8-channel multiplexer and microprocessor compatible control logic. The 8-bit A/D converter uses successive approximation as the conversion technique. The converter features a high impedance chopper stabilized comparator, a 256R voltage divider with analog switch tree and a successive approximation register. The 8-channel multiplexer can directly access any of 8-single-ended analog signals. The device eliminates the need for external zero and full-scale adjustments. Easy interfacing to microprocessors is provided by the latched and decoded multiplexer address inputs and latched TTL tri-state outputs.

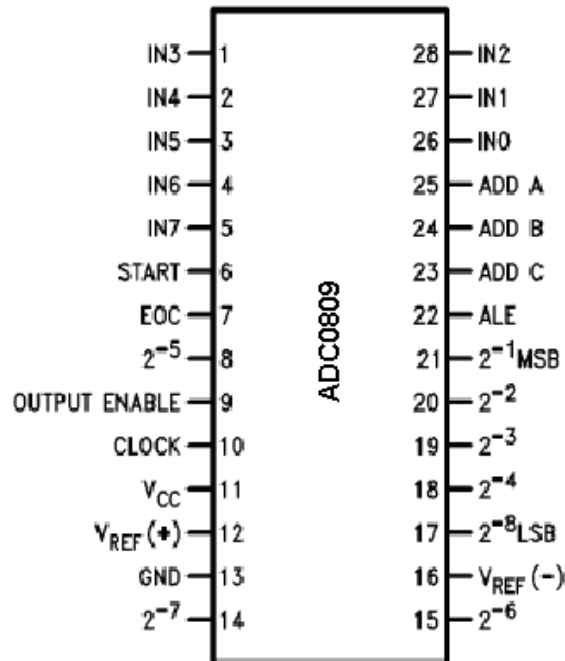

Figure 5.3 – Pin Configuration of ADC0809

Features of ADC0809

- Easy interface to all microprocessors
- Operates with 5 VDC or analog span adjusted voltage reference
- No zero or full-scale adjust required
- 8-channel multiplexer with address logic
- 0V to 5V input range with single 5V power supply
- Outputs meet TTL voltage level specifications

Multiplexer

The device contains an 8-channel single-ended analog signal multiplexer. A particular input channel is selected by using the address decoder. The address is latched into the decoder on the low-to-high transition of the address latch enable signal.

The A/D converter's successive approximation register (SAR) is reset on the positive edge of the start conversion (SC) pulse. The conversion is begun on the falling edge of the start conversion pulse. A conversion in process will be interrupted by receipt of a new start conversion pulse. Continuous conversion may be accomplished by tying the end of-conversion (EOC) output to the SC input. If used in this mode, an external start conversion pulse should be applied after power up. End-of-conversion will go low between 0 and 8 clock pulses after the rising edge of start conversion. The most important section of the A/D converter is the comparator. It is this section, which is responsible for the ultimate accuracy of the entire converter. It is also the comparator drift, which has the greatest influence on the repeatability of the device. A chopper-stabilized comparator provides the most effective method of satisfying all the converter requirements.

Digital to Analog Converter

The DAC0800 series are monolithic 8-bit high-speed current-output digital-to-analog converters (DAC) featuring typical settling times of 100ns. When used as a multiplying DAC, monotonic performance over a 40 to 1 reference current range is possible. The DAC0800 series also features high compliance complementary current outputs to allow differential output voltages of 20 V_{p-p} with simple resistor. The reference-to-full-scale current matching of better than ± 1 LSB eliminates the need for full-scale trims in most applications while the non-linearities of better than $\pm 0.1\%$ over temperature minimizes system error accumulations. The noise immune inputs of the DAC0800 series will accept TTL levels with the logic threshold pin, VLC, grounded. Changing the VLC potential will allow direct interface to other logic families. The performance and characteristics of the



device are essentially unchanged over the full $\pm 4.5\text{V}$ to $\pm 18\text{V}$ power supply range; power dissipation is only 33 mW with $\pm 5\text{V}$ supplies and is independent of the logic input states.

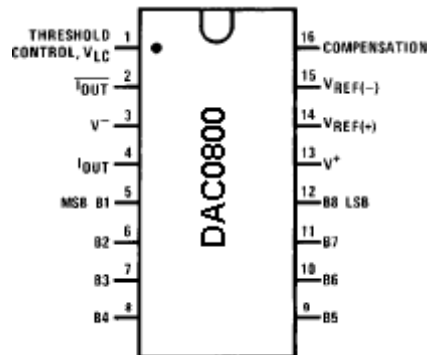

Figure 5.4 – Pin Configuration of DAC0800

Features of DAC0800

- Fast settling output current – 100ns
- Full-scale error – ± 1 LSB
- Non-linearity over temperature – $\pm 0.1\%$
- Full scale current drift – $\pm 10\text{ppm}/^\circ\text{C}$
- High output compliance – -10V to $+18\text{V}$
- Complementary current outputs
- Interface directly with TTL, CMOS, PMOS and others
- 2 quadrant wide range multiplying capability
- Wide power supply range – $\pm 4.5\text{V}$ to $\pm 18\text{V}$
- Low power consumption 33 mW at $\pm 5\text{V}$
- Low cost

Electromagnetic principles

Electromagnetic circuits can be thought of in a similar way to electrical circuits where the magneto motive force (MMF), flux and reluctance of a magnetic circuit are equivalent to the voltage, current and resistance respectively. Hence ohm's law for magnetic circuits is:

$$\text{MMF} = \Phi \cdot R \text{ Ampere turns}$$

Where Φ is the flux and R is the reluctance.

The reluctance of the object is related to the permeability of the material by:

$$R = \frac{l}{\mu_0 \mu_r A}$$

Where l and A are the length and cross sectional area of the material and μ_0 and μ_r are the permeability of air, and the relative permeability of the material. The energy density within a magnetic field is related to the reluctance through:

$$w = \int_B H dB \text{ Jm}^{-3}$$

Where H is the magnetic field intensity. The magnetic characteristics of a magnetic material are often displayed on a graph of B vs H. Here the reluctance is the slope of the B-H curve. It can be seen that the permeability decreases as the flux density increases and the magnetic material becomes saturated. The flux level where the B-H curve is flat shown in Figure 5.5 is known as saturation and operation in this region should be avoided.

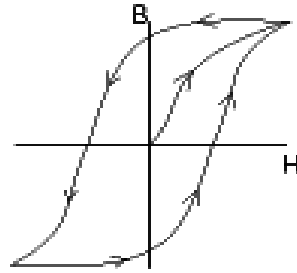

Figure 5.5 – B-H CURVE

There are only a few materials that exhibit good magnetic properties. Steel and ferrous irons are among the few known materials to have a relative permeability of greater than unity. Common values of relative permeability in steels are between 100 and 1000.

Solenoids

Solenoids are electro-mechanical actuators, which use a magnetic field to generate a force.

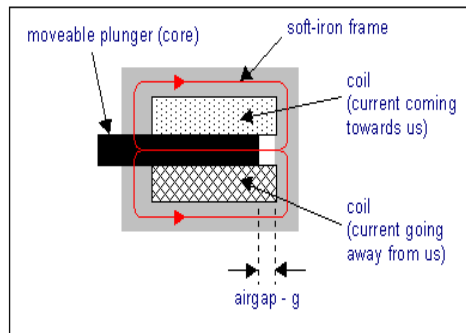

Figure 5.6 – Structure of a Solenoid

They consist of a coil of current carrying wire housed in a metal shell which, when

Energized, creates a magnetic force in a plunger. The force produced by the magnetic field is given by:

$$F = -\frac{1}{2} \Phi^2 \frac{dR}{dx}$$

Here the minus sign shows that the force acts to reduce the reluctance of the magnetic circuit. Assuming the permeability of the shell and plunger are much higher than that of the fluid in the gap, then the reluctance of the circuit is:

$$R = \frac{g}{\mu_o \mu_r 2\pi a h} + \frac{g}{\mu_o \mu_r 2\pi a x} = \frac{g}{\mu_o \mu_r 2\pi a} \left(\frac{1}{h} + \frac{1}{x} \right)$$

So,

$$\frac{dR}{dx} = \frac{g}{2\pi a \mu_o \mu_r} \left(-\frac{1}{x^2} \right)$$

And

$$\Phi = \frac{MMF}{R} = MMF \frac{2\pi a \mu_o \mu_r}{g} \frac{xh}{x+h}$$

Finally, the magnetic force in Newton is

$$F = \pi a \mu_o \mu_r \frac{MMF^2 h^2}{g} \left(\frac{1}{x+h} \right)^2$$



Where,

- g: the gap between the shell and the core
- h: Length of the shell limb (max travel of the piston)
- Φ : flux path, or path of least reluctance
- a: plunger radius
- x: position of the plunger relative to h

VI. CONCLUSION AND FUTURE SCOPE OF THE RESEARCH

Conclusion

Brake by wire is a technology to be used in many cars in the future courses. This technology will help integrate with other systems. This technology can be interfaced with other systems with communication channels using proper protocols. This system provides shorter stopping distances. Brake by wire is a technology easy to interface with automated highways. The electronics could be incorporated in a single chip to reduce the size of the ECU.

The electric vehicles are getting popular day by day and its speed also increases. Advanced braking system can be easily used in electric vehicles using this technology.

Future Scope

The Brake Assist System (BAS) need to have Antilock Braking System (ABS). As the brake force increases readily, the wheels tend to lock on slippery surfaces. To avoid this and provide shorter braking distance even on surfaces with low coefficient of friction, ABS needs to be used in conjunction with BAS.

The future scope also includes Electronic Stability Program (ESP). Braking of wheels can be controlled individually and the stability of the vehicle can be increased better. The roll, yaw and pitch of the vehicle need to be sensed with suitable sensors and ESP can be incorporated.

The system can also be incorporated with electric motor. High torque motors can be used for individual wheels with reduction gear and braking can be controlled. The position of the motor is sensed with a feedback from the encoder. This system proves to be a litter costlier than the electromagnetic brake system.

VII. REFERENCES

- [1] Brake Design and Safety – Rudolf, Limpert
- [2] Driving Safety systems – 2nd Edition (Society of Automotive Engineers)
- [3] Theory of Machines – R.S. Khurmi, J.K. Gupta, 2001 – Eurasia Publishing house Pvt. Ltd.
- [4] Sensors and Transducers – Society of Automobile Engineers
- [5] Automotive Mechanics – N.K. Giri
- [6] Research on a Brake Assist System with a Preview Function – SAE Paper No. 2001-01-0357
- [7] Brake-By-Wire: Solutions, Advantages and the Need for Standardization – SAE Paper No. 94C039
- [8] Development of the Brake Assist System – SAE Paper No. 980601
- [9] A New Approach to Investigate the Vehicle Interface Driver Brake Pedal Under Real Road Conditions in View of Oncoming Brake-by-wire-systems – SAE Paper No. 1999-01-2940
- [10] Advances and Challenges in Electronic Braking and Control Technology – SAE Paper No. 98224

Websites

- www.conti-online.com
- www.brakeassist.com
- www.freescale.com
- www.brakeclutch.com
- www.mayr.de
- www.vortex-clutch.com

CITE AN ARTICLE

Vignesh, P., Simmon, K. V., & Kumar, D. S. (n.d.). ELECTRONIC BRAKE ASSIST SYSTEM (EBAS) IN AUTOMOBILE WITH WIRE BRAKE. INTERNATIONAL JOURNAL OF ENGINEERING SCIENCES & RESEARCH TECHNOLOGY, 7(1), 433-454.